

# Sand-cement screeds and concrete toppings for floors



## 1. Introduction

Screeds and toppings are commonly used as a means of providing smooth flat floors in residential, commercial and industrial buildings. Toppings may also be used to increase the structural depth and strength of the base slab.

The aim of this publication is to provide the information needed by architects, engineers and contractors for specifying and laying floor screeds and toppings of acceptable quality.

In this publication three types of screeds and toppings are discussed:

- Monolithic screeds and toppings which are applied to the floor while the concrete in the base is still in a plastic state.
- Bonded screeds and toppings which are applied to hardened concrete floors.
- Unbonded screeds and toppings which are used when it is impossible to ensure a good bond between floor and screed or topping. In this case the screed or topping is separated from the floor by insulation boards or an impervious membrane.

## 2. Definitions

The following definitions are used in this document.

**Screed:**

A layer of well compacted material, commonly a mixture of cement and fine aggregate, that is applied to a base at the appropriate thickness and that has a surface suitable for receiving a floor finish.

**Topping:**

A layer of high-strength concrete designed:

- a) to provide a dense, abrasion-resistant surface on a concrete base, or
- b) to increase the structural depth and strength of a base



Levelling a concrete topping. Reinforcement and temporary screed battens in the foreground.

## 3. Specification

### 3.1 Suitability of screeds and toppings

Screeds are essentially light-duty flooring elements and are suitable for:

- Wearing surfaces of floors of utility rooms in domestic premises (e.g. store rooms, garages)
- Floors covered with carpets, plastic tiles or linoleum, etc. and subjected to relatively light traffic such as in offices, shops and hospitals

Screeds are generally not suitable as wearing surfaces in commercial buildings, schools etc. or in industrial premises. Preferred methods of floor construction for such premises are full-thickness trowelled concrete or a topping on a concrete base.

Screeds and toppings should be specified only where placing and finishing the concrete floor to acceptable standards is impracticable.

### 3.2 Surface finish

#### Screeds

The surface of the screed should be finished according to the type of wearing surface or flooring that is to be laid. For mastic asphalt, wood block and strip, and some textile floor coverings, a non-slip finish is appropriate, while thin sheet and tile floor coverings usually require a smoother, steel trowelled surface. If a designer specifies the use of a thin sheet or tile floor, then the use of a smoothing compound needs to be specified in certain circumstances.

#### Toppings

The surface of the topping should be finished to meet the abrasion requirements of the facility. Guidance is given in Table 3.

### 3.3 Specifying tolerances in levels and surface regularity

When specifying departure from datum and surface regularity, taking into account the types and thicknesses of the flooring and the screed or topping, the designer needs to consider:

- the finished floor surface;
  - the screed/topping/direct finished slab surface;
- the base slab to receive a screed or topping.

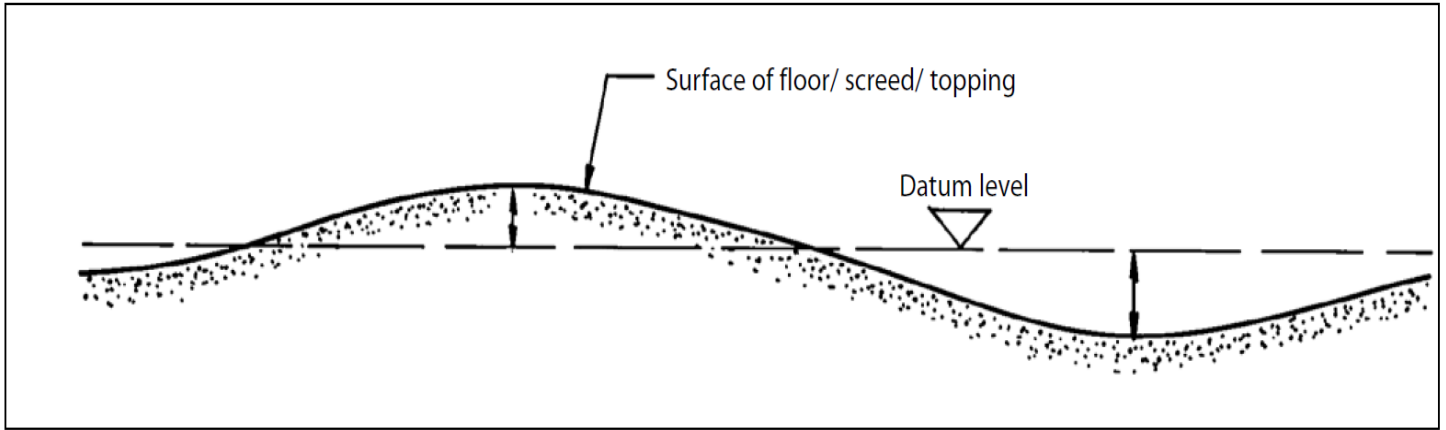

Figure 1: Deviation from datum level (Exaggerated vertical scale)

Some variations in surface regularity can be allowed without detriment to the satisfactory application of the flooring. The permissible limits associated with surface regularity and departure from datum depend on many factors. In general, the thinner the applied flooring the higher the class of surface regularity required.

Maximum permissible departure of the level of the screed or topping surface from datum and the required class of surface regularity should be included in the job specifications.

**Deviations from datum level (see Figure 1).**

Permissible deviation from datum level depends on the area of the floor and its intended use. For large areas for normal purposes  $\pm 15$  mm from datum should be satisfactory. Greater accuracy may be required in small rooms, along the line of

partition walls, in the vicinity of door openings, where specialized equipment is to be installed directly on the floor and in the case of high tolerance industrial floors.

**Surface regularity**

This is described as the maximum permissible deviation from a straight line 3 m long joining two points on the surface. See Figure 2. Values of deviation with corresponding class of surface regularity are given in Table 1.

The class of local surface regularity of a finish should be selected from those given in Table 1 according to the use of the floor. In making this selection, account should be taken of the type and thickness of the surface or flooring to be applied and the standard of surface regularity required of the finished floor. The highest standard (Class 1) should be used where a thin flooring is to be applied and where the minimum irregularity is required of the finished floor, e.g. for a television studio. In cases where a very flat floor finish is required, Class 1 using the straight-edge method, may not be adequate and other methods may have to be used (see *Further Reading* number 6). Conversely, the lowest type of wearing surface is applied where the regularity of the finished floor is not a significant factor. Insistence on higher standards of surface regularity than are necessary will result in higher costs.

In service, the suitability of a floor in terms of surface regularity is governed by its radius of curvature and changes in height over short distances. Specialist test equipment is now available with which to access these factors and new specifications can be used to control them (see *Further Reading* number 6). Although this new test equipment is more complex to use than the straightedge, it is less laborious on large floor areas.

Maximum permissible deviation from a 3 m long straight line joining two points on the surface (mm)	
3	Class 1; suitable for floors requiring minimum irregularity, e.g. television studios; may necessitate the use of special methods and will require close supervision
5	Class 2; suitable for the major proportion of construction work
10	Class 3; suitable for floors where regularity is not important

Table 1: Classification of surface regularity of floor

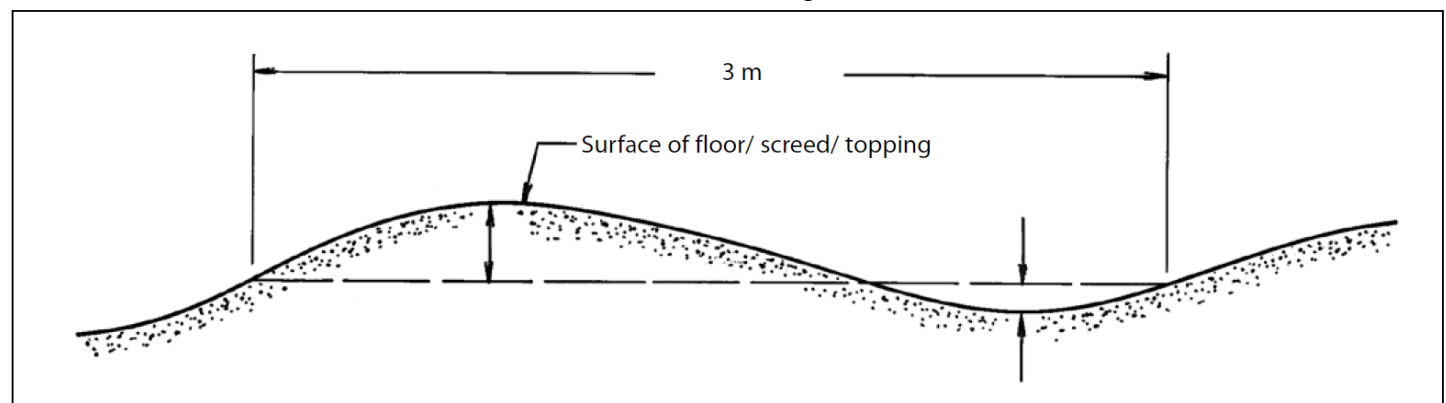

Figure 2: Deviation from a straight line 3 m long joining two points on the surface (Exaggerated vertical scale)

The designer should specify the maximum permitted abrupt change in level across joints in direct finished slabs and screeds and toppings taking into account the type and thickness of the flooring to be applied. For some types of floorings, a maximum of 2 mm would be acceptable, taking into account the surface preparation necessary to receive the flooring. For other types of flooring, especially thin floorings, or where no flooring is to be applied, it would be appropriate not to have any changes in level across joints.

Readings should be taken as soon as possible after completion of the screed or topping.

Various methods of specifying surface flatness and levelness are discussed in *Further Reading* number 7.

### 3.4 Specifying the strength of screeds and toppings

#### Screeds

The strength of a hardened sand-cement screed can be tested with the "BRE screed tester". Specifying an acceptance criterion before the start of the job is advisable as this could prevent disputes after completion.

The "BRE screed tester" consists essentially of a mass which is dropped on a standard foot piece which is placed on the surface of the screed. See Figure 3.

The indentation resulting from four impacts of the mass is measured and is an index of screed strength. Acceptance limits for various strength categories are given in Table 2.

#### Toppings

Concrete for a topping should have a characteristic 28-day compressive strength appropriate to the desired abrasion resistance (see Table 3), or designed compressive or flexural strength, but of at least 20 MPa where abrasion is not a consideration. The coarse aggregate used should be of nominal size 6,7 mm for monolithic toppings of nominal thickness 25 mm and of nominal size not exceeding 9,5 mm for separate bonded toppings of nominal thickness 30 mm. If the nominal thickness of the topping exceeds 40 mm, however, the nominal size of the coarse aggregate should be increased to one-quarter of the thickness of the topping, subject to a maximum of 19 mm.

## 4. Types of screeds and toppings

The three types of screeds and toppings to be discussed are:

- Monolithic screeds and toppings which are applied to the floor while the concrete in the base is still in a plastic state.
- Bonded screeds and toppings which are applied to hardened concrete floors.
- Unbonded screeds and toppings which are used when it is impossible to ensure a good bond between floor and screed or topping. In this case the screed or topping is separated from the floor by insulation boards or an impervious membrane.

While all three types have many characteristics in common, they also differ in some important ways. These are dealt with in the following sub-sections.

Maximum permissible depth of indentation after dropping the mass four times, mm	Strength category	Description
3	A	Areas expected to take relatively heavy traffic and/or where any disruption at a later date would be unacceptable; examples are hospital operating suites and corridors; rooms requiring microbe- or dust-free environment
4	B	Public areas such as lift lobbies, circulation areas within shops, foyers, canteens and restaurants; public rooms in residential accommodation; hospital wards
5	C	Offices, consulting rooms, domestic premises

**Table 2: Screed-strength acceptance limits using the "BRE screed tester"**

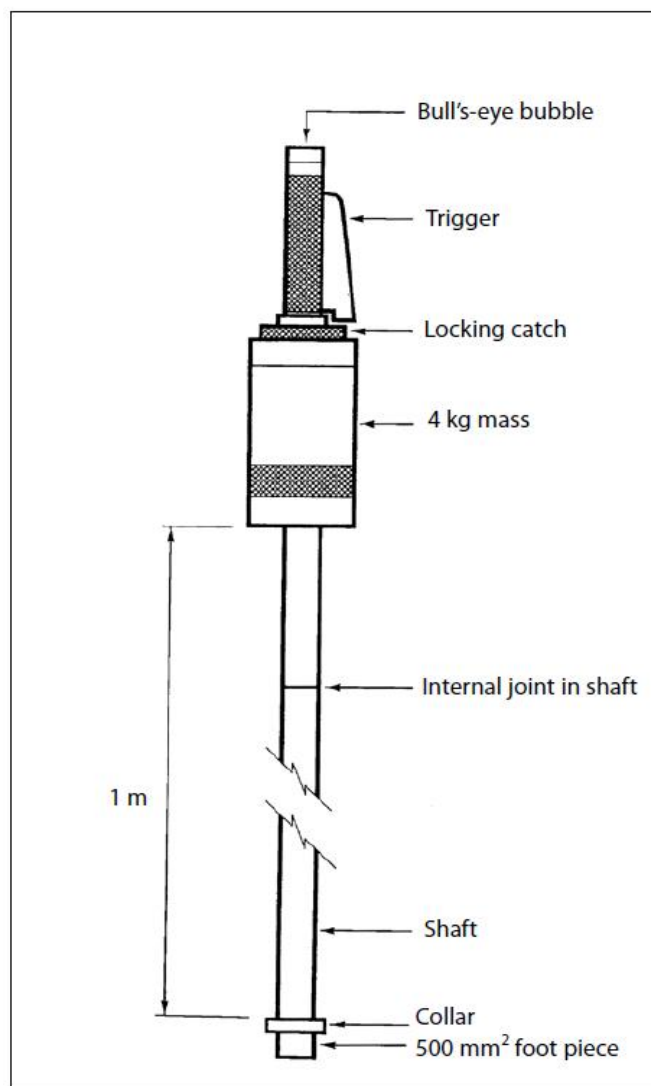

**Figure 3: "BRE screed tester"**

#### 4.1 Monolithic screeds and toppings

As defined above, these are screeds and toppings that are applied at the time when the underlying concrete floor is placed. Screed thickness should be approximately 25 mm but not less than 15 mm or more than 40 mm. The minimum thickness of a monolithic topping at any part should be 20 mm. The actual thickness required may depend on structural requirements. In some circumstances, the design thickness of a topping may have to be increased to more than 40 mm, but then there will be an increasing risk of loss of adhesion to the base, due to differential shrinkage stresses.

In attempting to achieve good adhesion between screed/topping and base concrete, it is important to take cognisance of the phenomenon of bleeding of fresh concrete. Bleeding causes water to accumulate on the top surface of the fresh concrete and the presence of this water layer may impair adhesion unless suitably dealt with.

The screed/topping should therefore be laid at one of two stages:

- either immediately the concrete has been compacted and levelled off and before bleed water appears on the surface (“immediate placing”);
- or after bleeding of the concrete has ceased and bleed water has evaporated or has been removed completely by mopping up (“delayed placing”).

**Immediate placing** requires careful timing but has the advantage that no preparation of the concrete surface is required.

Timing of **delayed placing** is not as critical but the surface of the concrete does require some preparation: laitance should be loosened by light brushing, with a wire brush or a brush with stiff bristles, and thoroughly removed by sweeping, or preferably, by vacuum cleaning. Delayed placing should however be done within an hour or two after the end of the bleeding period.

#### 4.2 Bonded screeds & toppings

As defined previously, bonded screeds and toppings are applied to hardened concrete. The hardened concrete is also known as the base concrete.

Screed thickness should be not less than 25 mm or more than 50 mm. The minimum thickness of a bonded topping at any part should be 35 mm. The actual thickness required may depend on structural requirements. In some circumstances, the design thickness of a topping may have to be increased to more than 60 mm, but then there will be an increasing risk of loss of adhesion to the base, due to differential shrinkage stresses. In these circumstances, the use of a reinforcing mesh (ref. 193 or 245) as close to the upper surface as is permissible will assist in restraining differential shrinkage and in controlling cracking.

**Table 3: Classification of abrasion resistance – recommendations for concrete finishes** <sup>[1]</sup>

1	2	3	4	5	6	7	Finishing process
Class	Service condition	Application	Type of finish	Concrete grade MPa	Type of coarse aggregate	Type of fine aggregate	
<b>Special</b>	Severe abrasion and impact	Very heavy duty engineering workshops, etc.	Proprietary toppings	Proprietary toppings cannot be classified by strength grade or minimum cement content, and may contain aggregates that do not comply with SANS 1083. Special finishing techniques may be used. The suitability of concrete bases in this class should be established with the manufacturer of the proprietary topping or with the contractor.			
<b>AR1</b>	Very high abrasion: Steel wheel traffic and impact	Heavy duty industrial, workshops, special commercial, etc.	High strength concrete toppings or proprietary toppings	50	Aggregates complying with SANS 1083 for concrete subject to surface abrasion	Sand complying with SANS 1083	trowelling twice or more, followed by curing
				When relevant, the suitability of concrete bases in this class should be established with the manufacturer of the proprietary topping or with the contractor.			
<b>AR2</b>	High abrasion, steel or hard steel or hard plastics wheel traffic	Medium duty industrial and commercial	Direct finished concrete bases with or without dry-shake finish, or concrete toppings	40 <sup>a</sup>	Aggregates complying with SANS 1083 for concrete subject to surface abrasion	Sand complying with SANS 1083	Trowelling twice, or early age grinding followed by curing
<b>AR3</b>	Moderate abrasion: rubber-tyred traffic	Light duty industrial and commercial	Direct-finished concrete bases with or without dry-shake finish	30 <sup>a</sup>	-	-	Trowelling twice followed by curing
<sup>a</sup> The grade may need to be higher for structural purposes.							

### Base-concrete requirements

The concrete on which the screed or topping is to be laid should be hard and strong (i.e. characteristic strength of at least 20 MPa). Weak, friable concrete is not suitable as a base for a screed or topping as the achievement of adhesion between such material and the screed or topping is not possible.

The base concrete should be free of random cracking. Floor screeds or toppings are unable to bridge over cracks in the base and such cracks will in time reflect through the screed or topping.

The surface of the base concrete should be reasonably accurate to the required level so that it is possible to place the screed or topping to a uniform thickness.

### Preparing the base concrete

The base concrete should be prepared in such a way that it is left with a surface that is uniformly hard, clean, and free of dust, oil or other contamination.

Any screeds or toppings applied previously to the base should be removed completely.

The laitance on the base concrete should be entirely removed by mechanical scabbling or scarification in order to expose cleanly the coarse aggregate. All loose debris, dirt, and dust should be removed using vacuum equipment.

These operations should be delayed until shortly before the screed or topping is laid, in order to prevent any contamination or accumulation of dirt.

### Bonding of screed or topping to base

The use of a sand-cement grout, if properly applied, should give good results and is described below. (If a proprietary bonding agent is used, it should be applied strictly in accordance with the manufacturer's instructions.)

The grout should consist of equal volumes of fine, clean sand and loose cement mixed thoroughly with sufficient water to achieve a consistence similar to PVA paint. It must be stirred continuously, and used within 30 minutes of making.

The day before laying of the screed or topping is to start (or earlier) the base concrete should be tested for absorptiveness by pouring about a cupful of water onto the surface.

If, during the next few minutes, it is clear that water is being absorbed, the suction of the concrete should be regarded as being high. In that case the procedure is:

- a) Wet the area on which the new screed or topping is to be laid and keep it wet for four hours or more.
- b) Remove all free water on the surface.
- c) Allow the surface to become visibly dry so that the base achieves a saturated surface-dry condition.
- d) Apply the grout to the surface.

On the other hand, if the test water is not visibly absorbed by the concrete during the first few minutes after application, the suction of the concrete should be regarded as being low and the grout may be applied to the dry concrete. Concretes with 28-day characteristic strengths of 25 MPa and over, if properly

compacted and cured, can be regarded as non-absorptive. In such cases, toppings have been successfully applied without a bonding grout provided the surface is clean and adequately prepared.

The grout may be slushed over the area where it is needed, but must then be worked thoroughly into the surface of the concrete by scrubbing with brushes and then brushed out to leave only a thin coating on the concrete without pools of grout in depressions. The brushes used for grouting should have bristles about 60 to 100 mm long and flexible enough to reach down into all the irregularities of the surface of the concrete. (Stiff "carpet" brushes are suitable, as are some garden brooms provided the base concrete is sufficiently even. Bass or yard brooms are not suitable because their bristles are too stiff and too close together. "Hair" brooms are too soft to be effective.)

Because the screed or topping mix must be laid on the grouted surface while the grout is still visibly wet, i.e. within 10 to 20 minutes of applying the grout, grouting must be done over small areas at a time, just ahead of laying of the screed. The grout must be made up in small quantities at a time, as needed.

**NOTE: Under no circumstances should the grout be allowed to dry out before placing the screed/topping as this will cause debonding. If there is any doubt about the possibility of a delay occurring, it is better to omit the grouting operation.**

## 4.3 Unbonded screeds and Toppings

### Screeds

Where screeds are, or have to be laid on a damp-proofing membrane or separating layer, the minimum thickness of the screed should be at least 50 mm. Where they are laid on a compressible layer, such as insulation boards, the minimum thickness should be at least 70 mm.

### Topping

Where a concrete topping is required over a damp-proof membrane, an unbonded overlay of minimum thickness 100 mm should be used in order to minimise the risk of curling. The grade of concrete for a direct-finished overlay should be in accordance with Table 3.

A similar unbonded overlay should be used where a base has become contaminated (e.g. with oil), and bonding is not possible.

The concrete used for an overlay intended to support a high strength concrete topping should have a 28-day compressive strength of at least 35 MPa.

## 5. Screeds in general

### 5.1 Materials for screeds

#### Sand

The quality of the sand, i.e. its concrete-making properties, has a large influence on the quality of the resulting screed. It should be a "concrete" sand – not a "plaster" sand – but the largest particles should be removed by sieving the sand through a sieve with openings about 5 mm wide to facilitate finishing.

Where possible, the sand should be tested in a laboratory beforehand. It should then, in a mix of 3,5 parts of dry sand and 1 part of cement by **mass**, produce a plastic, easy-working, cohesive mortar of plastering consistence (i.e. a slump of about 40 mm) with a water content per cubic metre of not more than 320 ℓ but preferably not more than 300 ℓ (The higher the water requirement, the lower the strength of the hardened screed and the greater the drying shrinkage and tendency to crack).

To produce a mix that is easy to finish to a smooth surface, it may be necessary to blend two or more sands. Commonly a blend consisting of 4 parts of crusher sand, sieved as above, and 1 part of a clean “plaster” sand, gives good results.

**Note: Sieving must be done on horizontal sieves which are shaken, or on cylindrical sieves which are rotated. The practice of throwing the sand onto a sloping sieve with a shovel is unacceptable because it is inaccurate, unreliable and wasteful.**

### Cement

All cement sold in South Africa must meet the requirements of SANS 50197 for Common cement or SANS 50413 for Masonry cement and the National Regulator for Compulsory Standards (NRCS) requirements as detailed in NRCS VC9085. Bags should be clearly marked with the strength grade, notation indicating composition and a Letter of Authority (LOA) number issued by the NRCS. An LOA is issued for each cement type from each source. To verify valid LOA numbers contact the NRCS on 012 428 5199 or [www.nrccs.org.za](http://www.nrccs.org.za).

**Note** that Masonry cements complying with SANS 50413 are not permitted to be used in concrete.

Use cement complying with SANS 50197-1 strength grade 32.5R or higher.

### Admixtures

Commercially available admixtures, especially of the water-reducing type, may be used, but preferably only on the recommendation of the laboratory which tests the sands, and only where adequate control of dosage on site can be guaranteed.

### 5.2 Batching

Mix proportions should be:

Sand, measured in the moist, loose state: 130 ℓ

Cement: 50 kg

Water: sufficient to achieve a plastic, workable consistence.

The capacity of a builder’s wheelbarrow is 65 ℓ so batches consisting of two barrow loads of sand and one bag of cement are convenient for mixing by hand or in a sufficiently large concrete mixer. The volume of compacted screed mix produced by such a batch is approximately 115 ℓ.

The size of the batch should never exceed the amount that can be used up within 45 minutes of mixing.

Apart from wheelbarrows, containers such as buckets, boxes or drums of known volumes may be used for batching. Batching containers should always be filled flush to the rim.

Sufficient containers for a complete batch should be provided to avoid the possibility of errors in counting.

Smaller batches may be made up as follows:

Sand measured in the moist loose state, ℓ	20	30	40	50	60	70	80	90	100	110	120
Cement measured in the loose state, ℓ	6	9	12	15	18	22	25	28	31	34	37
Water	Sufficient to achieve a plastic workable consistence										
Approx. yield, ℓ	18	27	35	44	53	62	71	80	88	97	106

### 5.3 Mixing

Machine mixing is preferable and each batch should be mixed for not less than three minutes if this method is used. With hand mixing, the sand and cement should be mixed without adding water until the colour is uniform. Then only may the water be added, the quantity used being just sufficient to produce a mix of the desired consistence. Hand mixing should be carried out with shovels on a smooth concrete floor or a steel plate.

Mixing directly on the ground should not be permitted as this results in contamination of the mix with earth and/or organic matter.

### 5.4 Placing and compacting

#### Control of levels

Narrow strips of screed mix, laid 3 to 4 m apart and compacted to finished level, should be used as guides to establish the level of the screed. The screed should be placed and compacted immediately after laying the guide strips.

Where the edge of a guide strip forms a day work joint it should be formed or cut to produce a vertical joint. Alternatively, and especially for bonded screeds, timber or metal screed battens, carefully levelled and trued, should be fixed at the correct height for the required thickness of screed. At day work joints all bedding screed beneath the battens should be cut away to form a vertical joint.

#### Panel sizes and joints

Screeds should be laid in areas as large as possible in one operation, consistent with achieving acceptable surface regularity and the levels required, to minimise the number of joints. Although screeds laid in large areas may crack at random intervals as they dry and shrink, these cracks are more acceptable than the curling which may occur at vertical butt joints if screeds are laid in small panels.

Where joints are present in the base concrete, they should be continued through the screed so that joints in screed and base line up exactly. Where screeds are placed on precast concrete elements this may not be practicable. In such cases, the use of a reinforcing mesh in the screed may be used to control cracking of the screed and applied floor finishes, along joints between precast units, provided panel sizes do not become excessive. This is particularly important if the applied finishes are brittle, or the slab is subject to external influences, such as thermal stresses, which could cause movement.

Joints may be formed with screed battens if screeds on each side are cast at different times, or by cutting through the partially stiffened screed mix with the edge of a trowel before the screed sets if both sides are laid at the same time. If the screed is not to be covered subsequently, edges at joints should be rounded to a 3 mm radius.

#### Time limits

The time which elapses between the start of mixing a batch and when that batch is placed and compacted should not exceed 45 minutes, and during that time the mix should be protected from drying out.

Batches not placed and compacted within this time, or which have stiffened to a degree that their workability (consistence) cannot be restored fully by turning them over a couple of times with spades, should be discarded.

#### Consistence of the fresh mix and means of compaction

It is essential that, during laying, the fresh mix be compacted fully. The consistence of the fresh mix and the means of compaction must therefore be matched to ensure that this is achieved. Generally therefore the fresh mix should be nearly as soft and plastic as a cement plaster (slump about 40 mm).

Spreading and compacting can then be done with relatively light timber screed boards operated by one or two workmen.

The screed mix should be dumped on the base concrete (freshly grouted in the case of bonded screeds) and spread somewhat thicker than the final required thickness. It should then be compacted using a screed board with a vertical chopping motion. Extra compaction with hand tampers is recommended along the edges of panels and adjacent to screed strips.

Once the screed has been compacted it should be taken to the correct level with a screed board riding on the screed strips or battens (or side forms in the case of monolithic screeds). The surface can then be wood floated to remove any ridges made by the screed board.

**Note: The use of stiff semi-dry mixes, laid with light screed boards, is a particularly common cause of weak screeds because such mixes are not adequately compacted. Semi-dry mixes can however produce very superior screeds, but only if they are compacted by power operated equipment such as vibrating screed boards and the consistence is correct.**

## 6. Toppings in general

### 6.1 Materials

#### Aggregates

Aggregates for concrete should comply with the requirements of SANS 1083. The coarse aggregate should be of nominal size 9,5 mm for a topping of nominal thickness 30 mm. However, if the nominal thickness of the topping exceeds 40 mm, the nominal size of the coarse aggregate should be increased to one quarter of the thickness of the slab, subject to a maximum of 19 mm.

#### Cement

All cement sold in South Africa must meet the requirements of SANS 50197 for Common cement or SANS 50413 for Masonry cement and the National Regulator for Compulsory Standards (NRCS) requirements as detailed in NRCS VC9085. Bags should be clearly marked with the strength grade, notation indicating composition and a Letter of Authority (LOA) number issued by the NRCS. An LOA is issued for each cement type from each source. To verify valid LOA numbers contact the NRCS on 012 428 5199 or [www.nrccs.org.za](http://www.nrccs.org.za).

**Note** that Masonry cements complying with SANS 50413 are not permitted to be used in concrete.

The choice of appropriate cement type depends on the type of floor and the environment in which it is to be used. Of prime concern are adequate early strength for cutting of joints and adequate abrasion resistance.

In floors with sawn joints, concrete has to achieve a certain strength to enable sawing of the joints. With mixes of low early strength, the time taken to reach this strength is increased. The longer the period between casting and sawcutting, the greater the possible moisture loss from the concrete and the higher the risk of shrinkage cracks occurring before the concrete can be sawn. Cement types and/or cement contents promoting sufficient early strength for sawing should be chosen.

Because floors have a large surface-to-volume ratio they are prone to rapid surface drying with the attendant loss of abrasion resistance at the surface. Effective curing is therefore essential.

Concrete made with cements having a low early strength or site blended cements may require adjustments in the concrete mix design to ensure adequate early strength for cutting of joints, particularly in cold environments. Curing methods and regimes may also have to be improved to ensure adequate abrasion resistance, especially in adverse weather.



**Pumping a concrete topping onto precast flooring. Reinforcement and screed battens in foreground.**

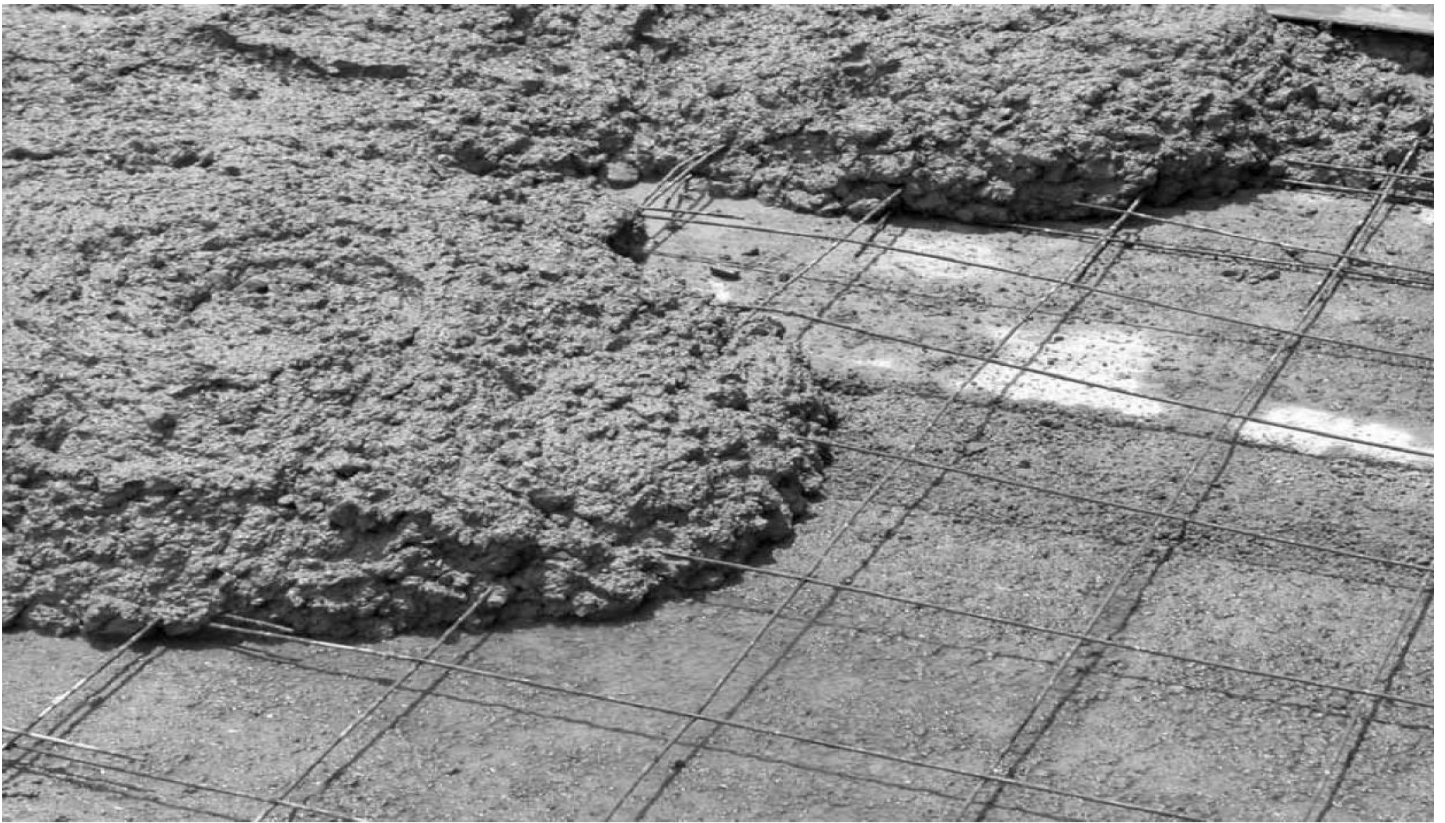

**Concrete topping being placed on a precast floor.**

#### **Admixtures**

Commercially available admixtures, especially of the water-reducing type, may be used, but preferably only on the recommendation of the laboratory which tests the sands, and only where adequate control of dosage on site can be guaranteed.

#### **6.2 Mixes**

A topping should have a characteristic 28-day strength appropriate to the desired abrasion resistance (see Table 3), or designed compressive or flexural strength, but of at least 20 MPa where abrasion resistance is not a consideration.

#### **6.3 Laying**

After screed battens surrounding the panels on which the topping is to be applied have been attached to the prepared base and the bonding agent has been applied as described above, the topping should be spread, compacted, screeded and bull floated as for a concrete floor.

#### **Panel sizes and joints**

##### ***Monolithic toppings***

Monolithic toppings should be laid in panels of the same size as those of the base.

Full-depth isolation joints should be formed in monolithic toppings against walls, columns and other fixed objects. Such joints should have the same width as those in the base, but not less than 20 mm.

Other joints in monolithic toppings should coincide with those in the base, be of the same type and width as those in the base and extend through the full depth of the topping.

##### ***Bonded toppings***

For separate bonded toppings the area of a panel should not exceed 9 m<sup>2</sup>. This may not be practicable for structural toppings on precast units where joints across the span within the central two-thirds of the span cannot be permitted. This may be overcome by the use of reinforcement as discussed later in this section. The general pattern of panels will depend upon such aspects as the shape of the floor area and the position of columns. Wherever possible, panels should be square, and the length of a panel should be limited to 1,25 times its width to reduce the tendency to crack.

Full-depth isolation joints should be formed in separate bonded toppings against walls, columns, and other fixed objects. Such joints should have the same width as those in the base, but not less than 20 mm.

Except where intermediate joints are required in the topping to divide it into smaller panels than the base, joints in separate bonded toppings should coincide with those in the base, be of the same type and width as those in the base and extend through the full depth of the topping. Intermediate joints dividing the topping into panels of recommended maximum dimensions should be either sawn contraction joints that extend halfway through the thickness of the topping, or butt construction joints.

Where bonded toppings are placed on precast concrete elements and the above recommendations are not practicable, the use of a reinforcing mesh close to the top surface of the topping may be used to control differential shrinkage and cracking of the topping and applied floor finishes along joints between precast units, provided panel sizes do not become excessive. The larger the panel size and the thicker the topping, the greater is the amount of steel required.



**Power floating a screed.**

### ***Unbonded toppings***

The maximum panel size of a separate unbonded overslab should be based on the following rules:

- Maximum joint spacing not to exceed 30 times overslab thickness, or 4,5 m, whichever is the lesser
- Length-to-width ratio of panels not to exceed 1,25

Full-depth isolation joints should be formed in a separate unbonded overslab against walls, columns and other fixed objects. Such joints should have the same width as those in the base, but not less than 20 mm.

Other joints should be either sawn contraction joints that exceed a depth of one quarter of the slab thickness, or keyed construction joints. Both types of joint should be offset at least 300 mm from those in the base.

### **Time limits**

The time which elapses between the start of mixing a batch and when that batch is placed and compacted should not exceed 45 minutes, and during that time the mix should be protected from drying out.

Batches not placed and compacted within this time, or which have stiffened to a degree that their workability (consistence) cannot be restored fully by turning them over a couple of times with spades, should be discarded.

## **7. Finishing**

The resistance to wear of a concrete finish is significantly influenced by the method of finishing and the care with which finishing is carried out. Under no circumstances should cement or a dry cement-sand mixture be sprinkled directly onto the surface of a finish in order to absorb bleed water or laitance, since defects such as surface scaling may occur later. Surface water should not be trowelled back into the finish and, similarly, water should not be applied between trowelling operations, since this may cause surface weakness.

Three types of surface finish are described below, the choice being made according to circumstances.

### **7.1 Ordinary non-slip**

The surface is left as finished with wooden floats, except that if it is too open or too coarse it may be given a few passes with either Perspex or aluminium floats to close the surface without smoothing it. Over-working should be avoided.

### **7.2 Steel-trowelled**

If a hard, smooth finish is required, the surface will have to be steel-trowelled, using the delayed trowelling method.

After the screed or topping has been spread, compacted and screeded to level, it should be bull floated.

Bull floating should immediately follow screeding and should be completed before any excess moisture or bleed water is present on the surface. The purpose of bull floating is to eliminate ridges and fill voids resulting from straight-edging.

Before further steps are taken, the finish should be left undisturbed (the delay period) until bleeding has ceased, the surface has stiffened to the extent that a footprint will barely show, and surface water has either evaporated or been removed.

Following the delay period, the finish should be floated again.

The purpose of floating is:

- a) to depress large aggregate below the surface,
- b) to remove slight imperfections, lumps and voids and to produce a level or plane surface, and
- c) to compact the finish and consolidate mortar at the surface in preparation for other finishing operations.

Floating and trowelling may be carried out by hand or mechanically. When floating is done mechanically, either a disc-type float or a trowelling machine with float shoes attached should be used.

Trowelling should be done immediately after floating. The purpose of trowelling is to produce a smooth, hard surface. For the first trowelling, the trowel blades should be kept as flat against the surface as is practicable. As the surface stiffens, each successive trowelling should be made with smaller trowels tilted progressively more to increase the compaction of fines at the surface, giving greater density and more wear resistance.

The resistance to abrasion increases with the number of trowelling operations and the care with which they are carried out. The operations should be timed to prevent an excess of laitance being produced at the surface. For the highest abrasion resistance, final trowelling should be made when considerable pressure is required to make any impression on the surface. However, excessive trowelling at this stage should be avoided, to prevent a polished or slippery surface.

### **7.3 Finishes that are not to be exposed to severe service conditions**

The finish (after it has been spread, compacted, screeded to level, and floated) should be left undisturbed until bleeding has ceased and the finish has stiffened to the extent that a footprint will barely show. Surface water should then be removed from the surface, floated and steel-trowelled at intervals until the desired texture is achieved.

The texture of concrete finishes can be varied from a fine matt to a glossy surface, depending on the number of trowellings applied. A coarse non-slip texture may be produced by brushing a freshly floated surface with a broom, but the resulting ridges may become subject to abrasion.

Trowelling too soon and over-trowelling should both be avoided, since they bring to the surface a thin layer rich in cement, which tends to craze and release dust particles.

## **8. Curing**

Concrete has to be effectively cured if maximum surface strength, maximum resistance to surface abrasion and low impermeability of the concrete are to be attained, and the development of drying shrinkage cracks is to be avoided or minimised. Effective curing also reduces the effect of differential shrinkage, and therefore curling, by delaying the effect of differential drying until the concrete is better able to resist its effects.

Curing should start as soon after final finishing as practicable, and should be done by one of the following methods:

- a) uniform application of a liquid membrane-forming curing compound at an approved rate for complete coverage, always taking into consideration the manufacturer's instructions. Curing compounds should comply with the requirements of AASHTO M148 and should be of type 1-D or type 2. (This method may not be suitable where other finishes are to be applied.)
- b) ponding
- c) covering with thick hessian or similar clean moisture retaining and non-staining material that is kept wet
- d) covering with polyethylene or similar vapour-proof material in large sheets, sealed at the edges of the finish and at the side laps of the sheeting

To prevent surface damage to trowelled and other finishes, it may be necessary to suspend the coverings described in (c) and (d) above, clear of the surface until such time as they can be placed directly onto the surface. Care should be taken to prevent wind tunnelling under coverings.

Curing should continue for at least 7 days. In cold weather, this period should be extended. Cold weather may be deemed to be conditions in which the "average" ambient temperature falls below 10 °C, where "average" is defined as the arithmetic mean of the maximum and minimum ambient temperatures recorded on site within a period of 24 hours. During cold weather, the curing period should be extended by 0,5 days for each day in which the average ambient temperature falls to between 5 °C and 10 °C, and by 1 day for each day in which the average ambient temperature falls below 5 °C.

## **9. Material quantities**

### **9.1 Screed**

The net approximate quantities of materials required to manufacture 1 m<sup>2</sup> of compacted screed mix 25 mm thick are:

Sand in moist, loose state: 28 ℓ

Cement: 11 kg

An allowance of 10% over and above these quantities should be made for wastage.

### **9.2 Grout**

For bonded screeds, allow about 1 kg of cement and 1 ℓ of plaster sand per m<sup>2</sup> of screeded area for the grout.

## 10. Inspection and testing of toppings and screeds

### 10.1 Inspection

Before the finishing work is started, the base should be checked for any departure from level, to ensure that the minimum thickness of finish can be applied.

The work should be inspected during progress and after completion, attention being paid to the following points:

- a) materials
- b) preparation of the base, where the finish is to be bonded
- c) batching and mixing
- d) proper compaction
- e) correct finishing
- f) correct curing
- g) making and curing cubes (see SANS 5861-3) for both topping and screed mixes

### 10.2 Testing of the completed work

After completion of the work, the following tests should be carried out:

- a) levels and surface flatness of toppings and screeds
- b) adhesion of bonded screeds and toppings to the base
- c) curling and lipping of unbonded screeds
- d) soundness of bonded and unbonded screeds
- e) testing (see SANS 5863) for cubes

#### Levels and surface flatness

Deviation from datum may be checked with conventional survey instruments.

The testing of surface regularity will depend on the type of specification used. It may be tested by straightedge, precise levelling or other specialised equipment.

A straightedge at least 3 m long can be used to check surface regularity. It should be supported on two rigid blocks of identical height (say 15 mm) placed 3 m apart on the screed surface. Deviations of the screed surface from the straight line joining the points at which the blocks are placed may be measured with suitable slip or feeler gauges. Alternatively, specialist methods may be used (see further reading number 6).

#### Adhesion between separate bonded toppings or screeds and a base

The adhesion between the topping or screed and the base should be examined by tapping the surface with a rod or a hammer, a hollow sound indicating lack of adhesion.

Tests to check the adhesion of a screed or topping to its base should be made as late as possible in the construction programme when the maximum effect of drying shrinkage has taken place. Account should be taken of the time for any replacement sections of screeds and toppings to be laid within the construction programme.

#### Curling and lipping of toppings and screeds

Toppings and screeds should be considered unsatisfactory if they have lifted by a visible or measurable amount at joints and cracks, to the extent that there is a risk of fracture under imposed loads.

## Strength

### Screed

The "BRE screed tester" (see Figure 3) is used to assess strength once screeds are at least 14 days old and have dried out. No less than three tests should be carried out in each area less than 20 m<sup>2</sup> and on each 20 to 25 m<sup>2</sup> of screed laid in larger areas. Corridors should be tested at 3 to 5 m intervals.

Test positions should be selected at random, but vulnerable areas adjacent to panel joints and any shrinkage cracks, and in doorways, should be tested. Where test indentations exceed those specified using the values in Table 2, additional tests should be carried out to determine the zone of non-compliance.

Test procedure is as follows:

- a) Select a sensibly flat, smooth area of screed and remove all loose dirt and grit.
- b) Use the template supplied with the tester to mark the test position of the feet of the depth-measuring device and take the zero reading.
- c) Locate the foot piece of the screed tester at the test position in contact with the screed.
- d) With the guide rod held vertically, deliver four successive blows of the mass to the foot piece at the same position on the screed, dropping the mass freely from the trigger point each time.
- e) After the fourth blow, measure the depth of the final indentation in the screed with the depth measuring-device.

### Topping

The "BRE screed tester" is not suitable for use on high-strength concrete toppings. The strength of such toppings is determined by testing cubes taken at the time of laying, or by tests performed on samples taken from the finished topping.

#### Assessment of cracks and curling

Cracks should be assessed in relation to the area involved and the flooring to be applied, and likely future movement.

Fine cracks are not normally detrimental to any applied flooring and do not need filling; wider cracks may need filling or other remedial work.

Loss of adhesion does not necessarily mean that the screed or topping is unsatisfactory. It may, however, be critical in the case of structural toppings.

Those areas of the screed or topping that are considered to be unsatisfactory should be isolated by sawing, removing and re-laying. Care should be taken to minimise the effect that any cutting-out operations may have on the adhesion of adjacent parts of the screed.

An alternative method that is less disruptive and may be suitable in some circumstances, is by injection of a low-viscosity epoxy resin into the crack and the gap under the screed or topping. This operation must, however, be carried out by a specialist.

## 11. Further reading

1. SANS 10109-2:2013, **Concrete floors. Part 2: Finishes to concrete floors**, Pretoria: Standards South Africa, 2013.
2. SANS 10155:2009, **Accuracy in buildings**, Pretoria: Standards South Africa, 2009.
3. SANS 2001-CCI:2012, **Construction works. Part CC1: Concrete works (structural)**, Pretoria: Standards South Africa, 2012.
4. Roberts, R.F. **Testing cement-sand screeds using the BRE screed tester**, Wexham Springs: Cement and Concrete Association, 1986. (C&CA Guide 48.057).
5. BS 8204-1:2003, **Screeds, bases and in-situ floorings. Part 1: Concrete bases and cement sand levelling screeds to receive floorings – Code of practice**, London: British Standards Institution, 2003.
6. The Concrete Society, **Concrete industrial ground floors: a guide to their design and construction**, 3rd ed. Crowthorne: The Society, 2003. (Technical Report no. 34).
7. Marais, LR and Perrie, BD. **Concrete industrial floors on the ground**, Midrand: Portland Cement Institute, 1993.
8. BS 8204-2:2003, **Screeds, bases and in-situ floorings. Part 2: Concrete wearing surfaces – Code of practice**, London: British Standards Institution, 2003.

Cement & Concrete School of Technology, its directors, officers, employees, representatives and agents are not liable for any death, harm or injury caused to any person or any loss, destruction or damage caused to any person's property or possessions arising from goods supplied or services rendered by

**Cement and Concrete School of Technology**

Published by: Cement & Concrete School of Technology,  
Midrand, 2024

© Cement and Concrete School of Technology